

Multiple Zone Stimulation of EGS Wells - Key to Reservoir Optimization

***Geothermal Energy Utilization Associated
with Oil and Gas Development***

SMU

June 13-15, 2011

***Susan Petty, Daniel Bour, Yini Nordin,
Laura Nofziger - AltaRock Energy Inc.***

Outline

- Introduction - Geothermal & EGS Power
- EGS Lessons Learned
- Current Stimulation Technology
- Reservoir Optimization
- Temporary Diverters
 - Benefits
 - Design
 - Application
- GETEM Modeling Results
- Description of Operations
- Outcome & Conclusions

Geothermal Energy - What is it?



The deeper you go the hotter it gets



Heat Stored in Rock

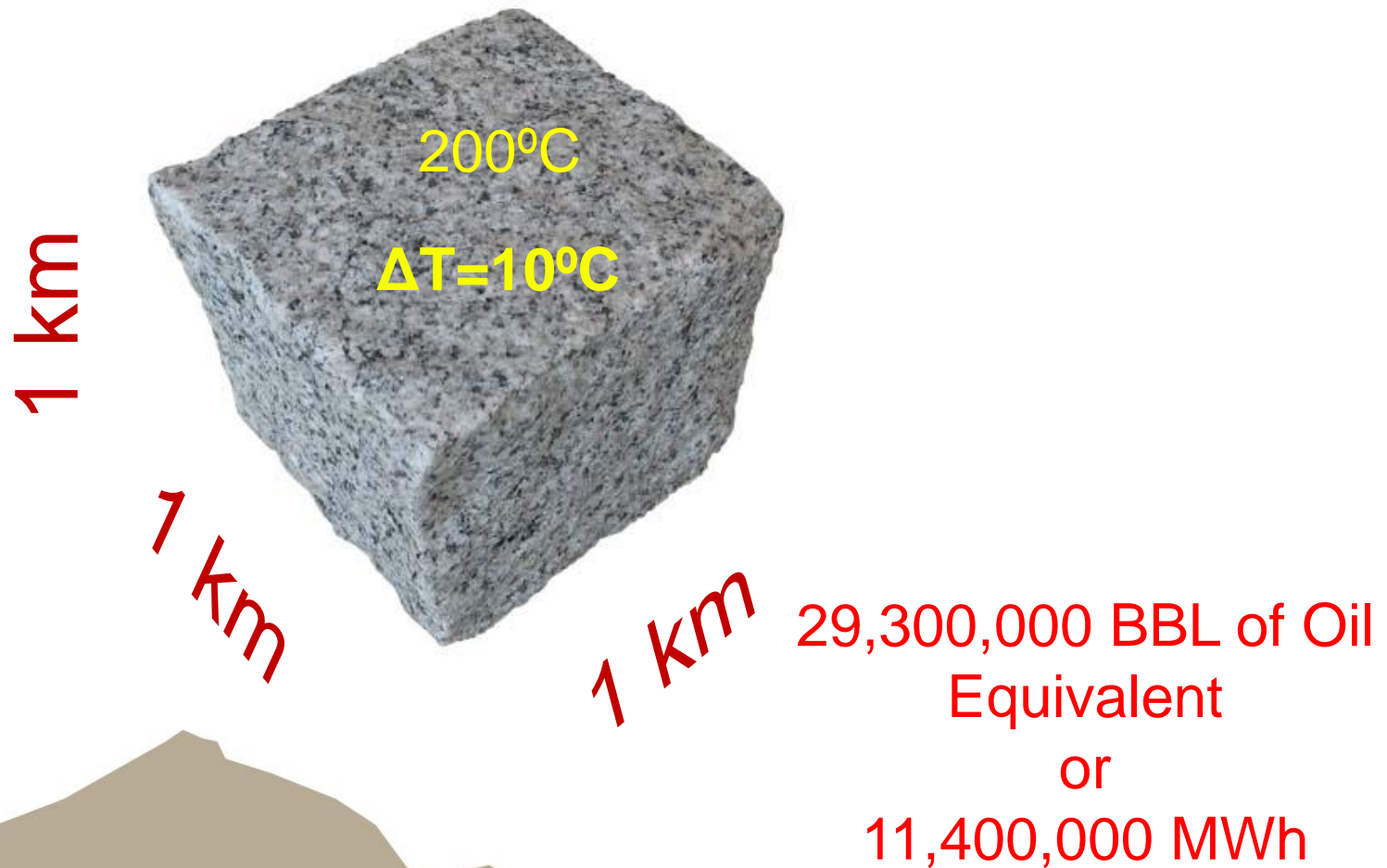

How an Enhanced Geothermal System Works

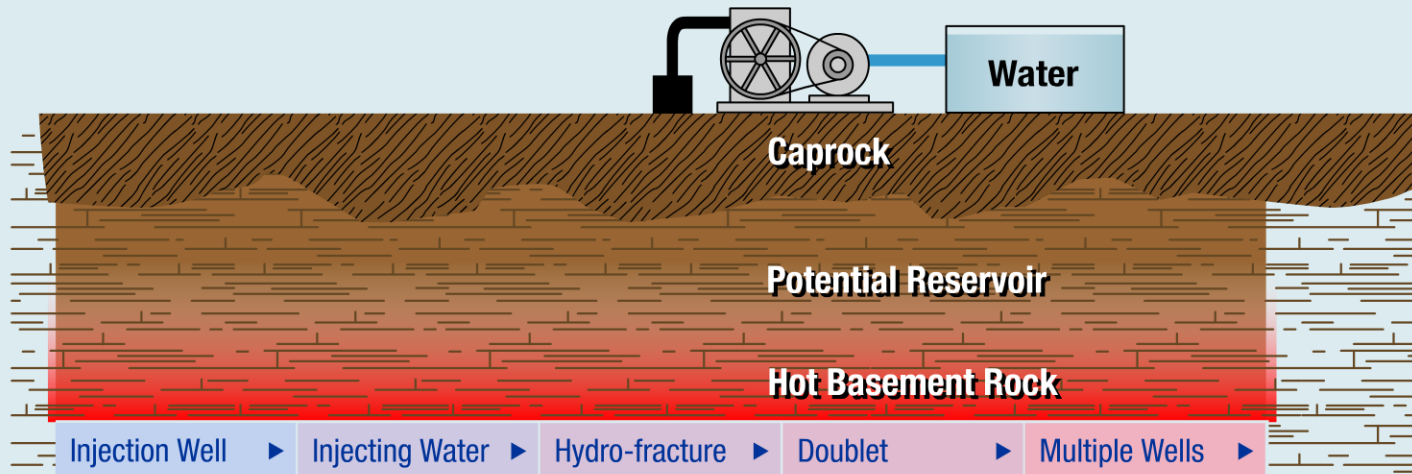

Introduction

Today, geothermal power is produced from geothermal resources that have a combination of three critical factors; 1) high-temperature rock, 2) water saturation of the field, and 3) good permeability to allow water (the heat transfer agent) movement throughout the target geothermal field.

Tapping suitably hot rock that is dry (lacking in fluid saturation due to impermeability) can vastly increase our geothermal energy resource. This diagram shows how all three factors interact, and how a new geothermal field can be realized by increasing permeability through hydro-fracturing stimulation.

Click on the colored buttons above to better understand the process of how enhanced geothermal systems (EGS) are created.

Producing Doublet Wells

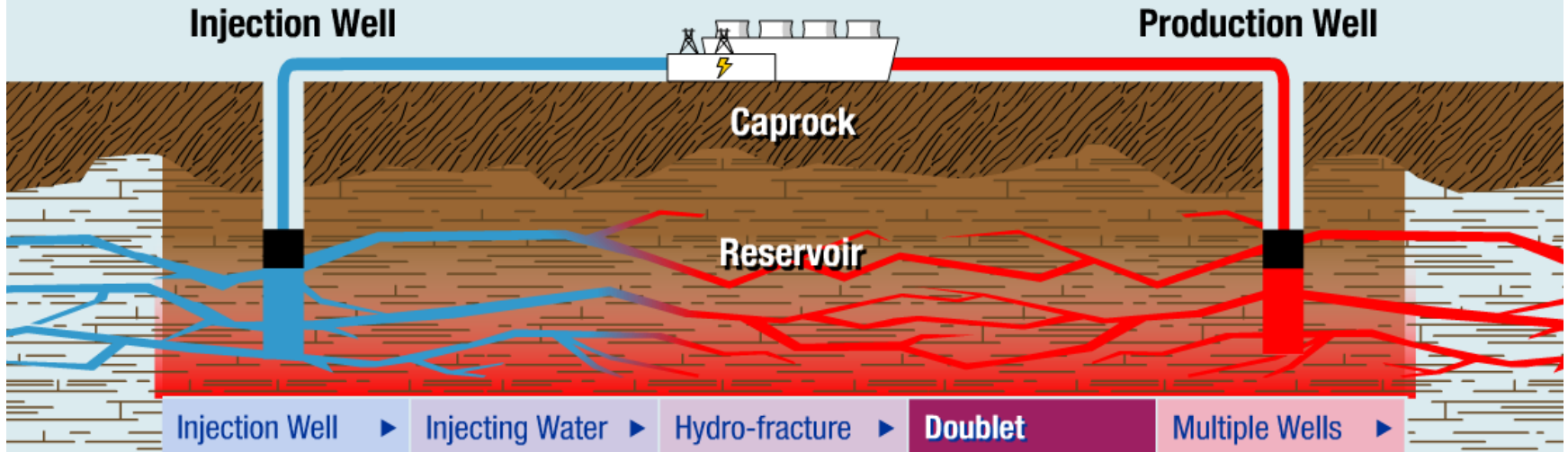

Doublet

A production well is drilled with the intent to intersect the stimulated fracture system created in the previous step, and circulate water to extract the heat from the hot basement rock with improved permeability.

Worldwide EGS Lessons Learned

Project	Timeline	Deformation Mode on Fractures	Thermal Output (MWe equiv)	Problems encountered
Fenton Hill	1974-1992	Tensile/Shear	3	Reservoir connection was inadequate, caused by unanticipated shift in fracture mode and predominant orientation. Better stimulation methods and down-hole pumping equipment needed. Drilled 2 wells prior to stimulation. Used O&G Fracture fluids and sand/proppant.
Rosemanowes	1977-1991	Tensile	0.5	Hydraulically fractured and found that best fracture connection in an EGS reservoir is created by shearing pre-existing fracture joint sets. High applied injection pressure also resulted in continued fracture growth, leading to water loss and short circuits.
Hijiori	1987-2002	Tensile	1	It is difficult to connect two wells through stimulation. Best practice is to stimulate and map the seismicity during stimulation of existing well and drill the second well into the seismic cloud in order to intersect multiple fractures
Soultz	1986-present	Shear	1.5	Limited connection resulting in limited production rates. Only one zone per well. Low reservoir temperature.
Cooper Basin	2001-present	Tensile/Shear	6	Limited to one stimulation zone at a time. Packers used to isolate stimulation zones. Need other zonal isolation technologies
Coso	2001-present	Shear		Limited zonal isolation. Stress rotation due to active fault.
Desert Peak	2001-present	Tensile		Set packs in order to achieve zonal isolation. Increased risks.

Worldwide EGS Lessons Learned

- First well needs to be drilled and stimulated in order to design the entire system
- Stimulation is through shearing of pre-existing fractures instead of creating new tensile fractures
- High flow rates with long path length are needed
- Need technology for multiple zone stimulation
 - We currently do not have reliable open-hole packer for zonal isolation

Current Stimulation Technology

- Inject fluid from the surface
- Most permeable zone in well takes fluid and is stimulated
- Remaining zones only take limited amounts of fluid.
- Increasing flow by increasing injection pressure risks induced seismicity

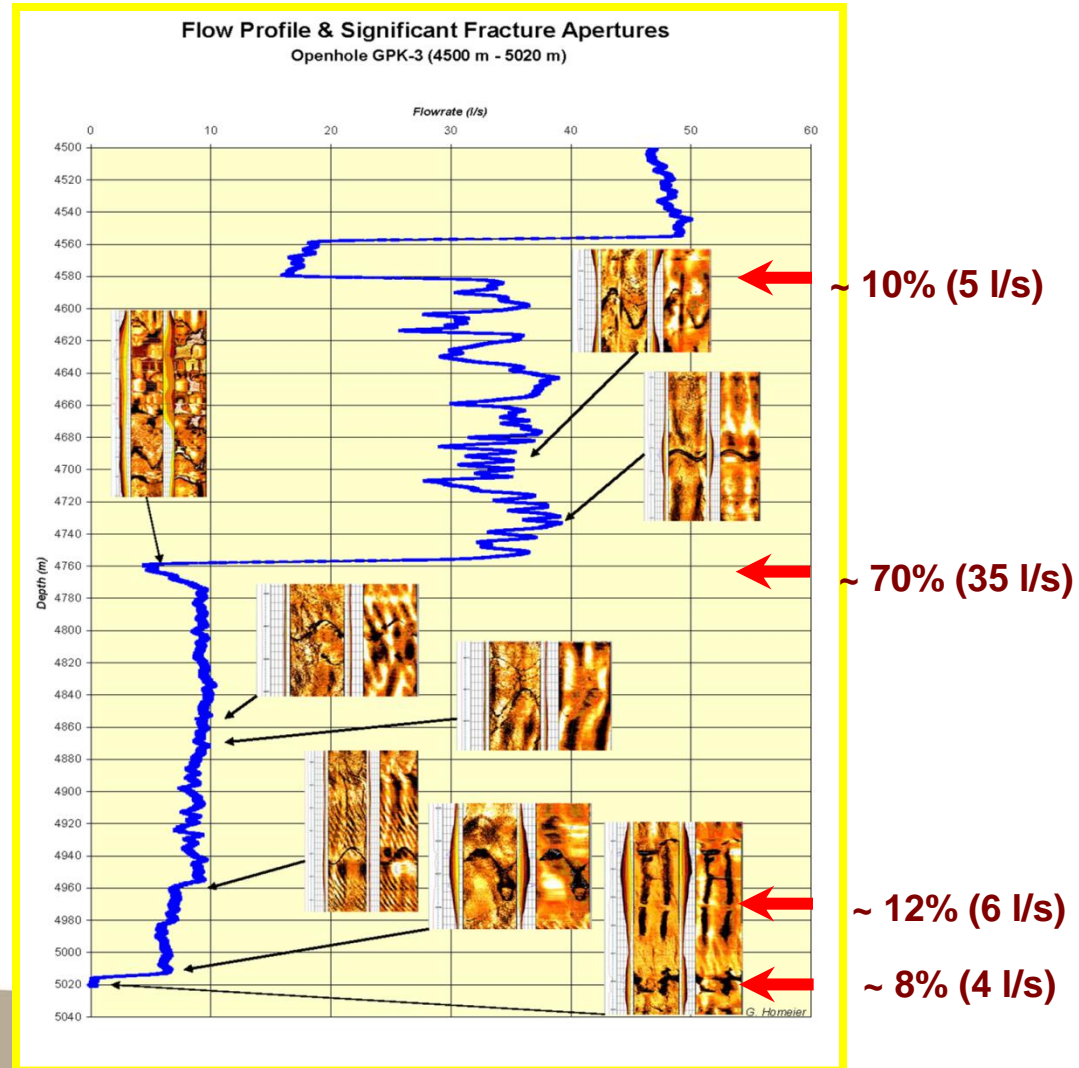

Reservoir Optimization

Single Fracture Network

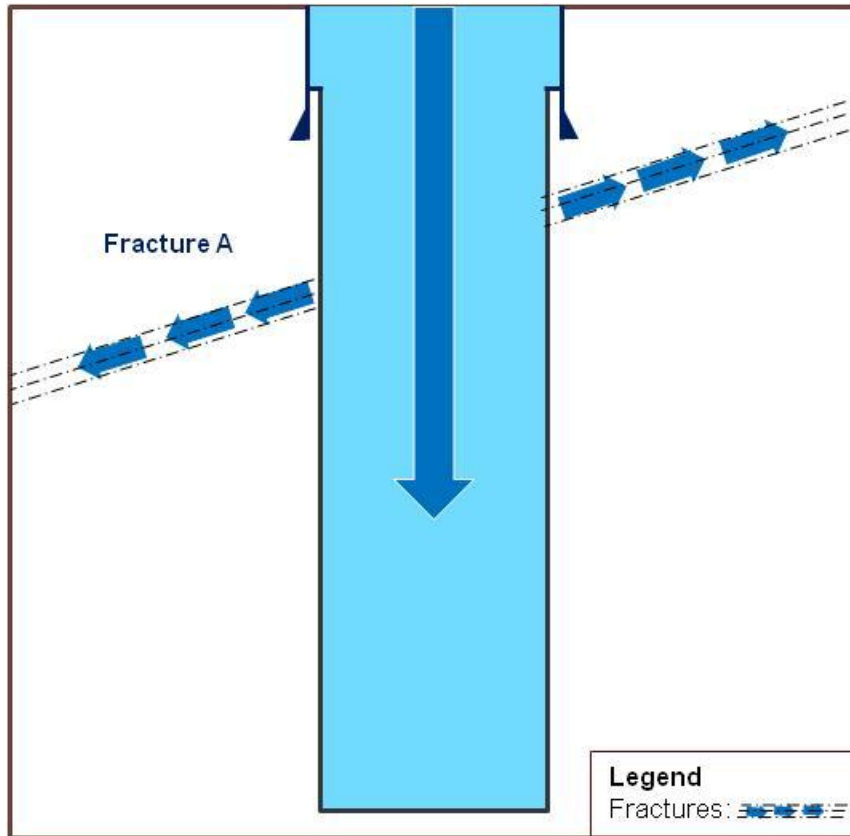

Limitations of Single Fracture

- Flow through a single stimulated fracture network provides minimal heat exchange area
- Flow rates are then limited by the maximum injection pressure which will extend fractures
 - Increase the rate of cooling at the production well
- Large portion of reservoir rock intersected by well are left untapped for heat extraction and power production

Reservoir Optimization

Benefits of Multiple Fractures

- Multiple fractures allow for flow through two or more fracture networks
- More rock heat exchange area is contacted
- Pressure drop through system is reduced allowing higher flow rates
- Additional flow will allow for greater production on a per well basis

Multiple Fracture Network

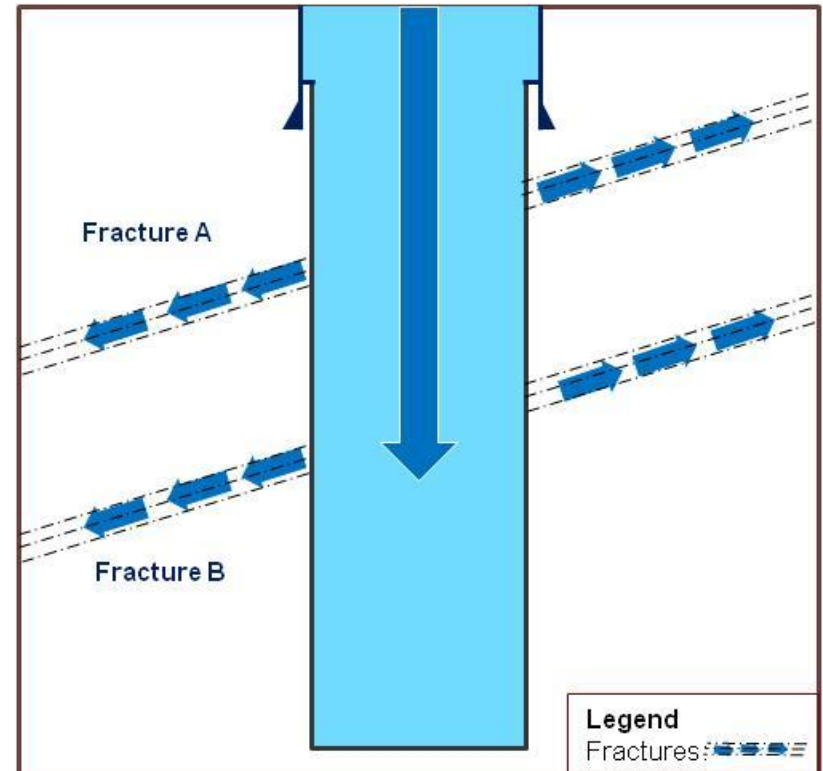

GETEM Modeling Results

- **Inputs**

- 30 kg/sec base flow
- 4 km depth well

- **Results**

- Flash system had 40% reduction in power cost
- Binary system had 50% reduction in power cost

Flash/Binary	Temperature (° C)	Improvement	Cost of Power 2010 (cent/kw)
Flash	250	N/A	11.53
Flash	250	3x flow rate	6.88 (40% Less)
Binary	175	N/A	31.94
Binary	175	3x flow rate	16.02 (50% Less)

Temporary Diverters

Diverter Sealing Zone

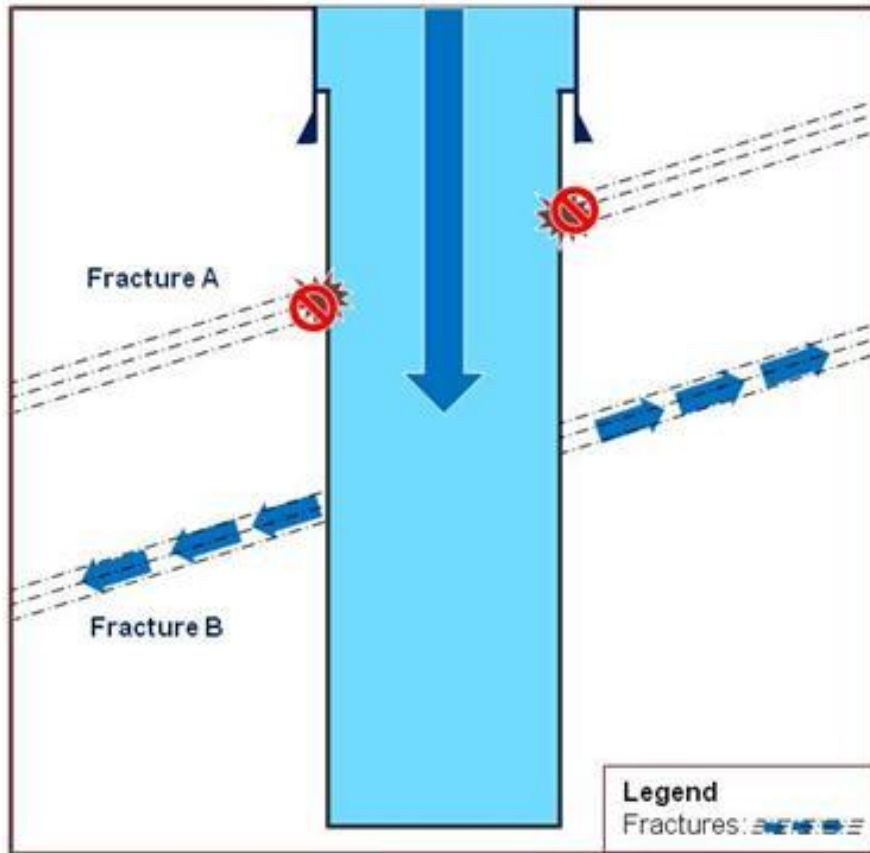

Degraded Diverter

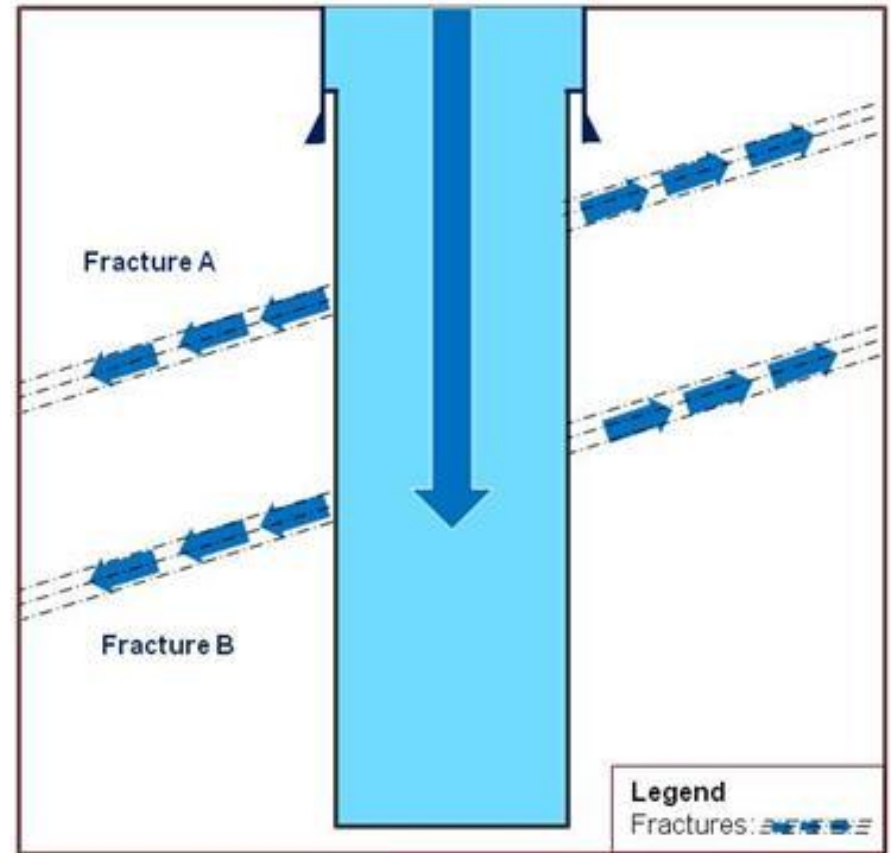

AltaRock Proprietary Temporary Diverters

Design

- Particle size distribution of material that will allow for packing and sealing of fracture
- Remain in place and withstand differential pressure during 2nd stimulation
- Degrade to non-damaging products after stimulation as well heats back up
- Require instruments in hole during treatment to monitor and verify that diversion has occurred

Benefits

- Increased production reduces cost of power production
- No Rig required during treatment
 - Major cost Savings
 - Reduce Operational risk
 - Create fractures in succession without moving packer and waiting on rig
- Can be used even when slotted liner is in place
 - Cannot use mechanical isolation like packers in well with slotted liner

Temperature Modeling

Thermal Cooling from Injection - 10 bpm

Temperatures vs. Time - Injection - Annulus

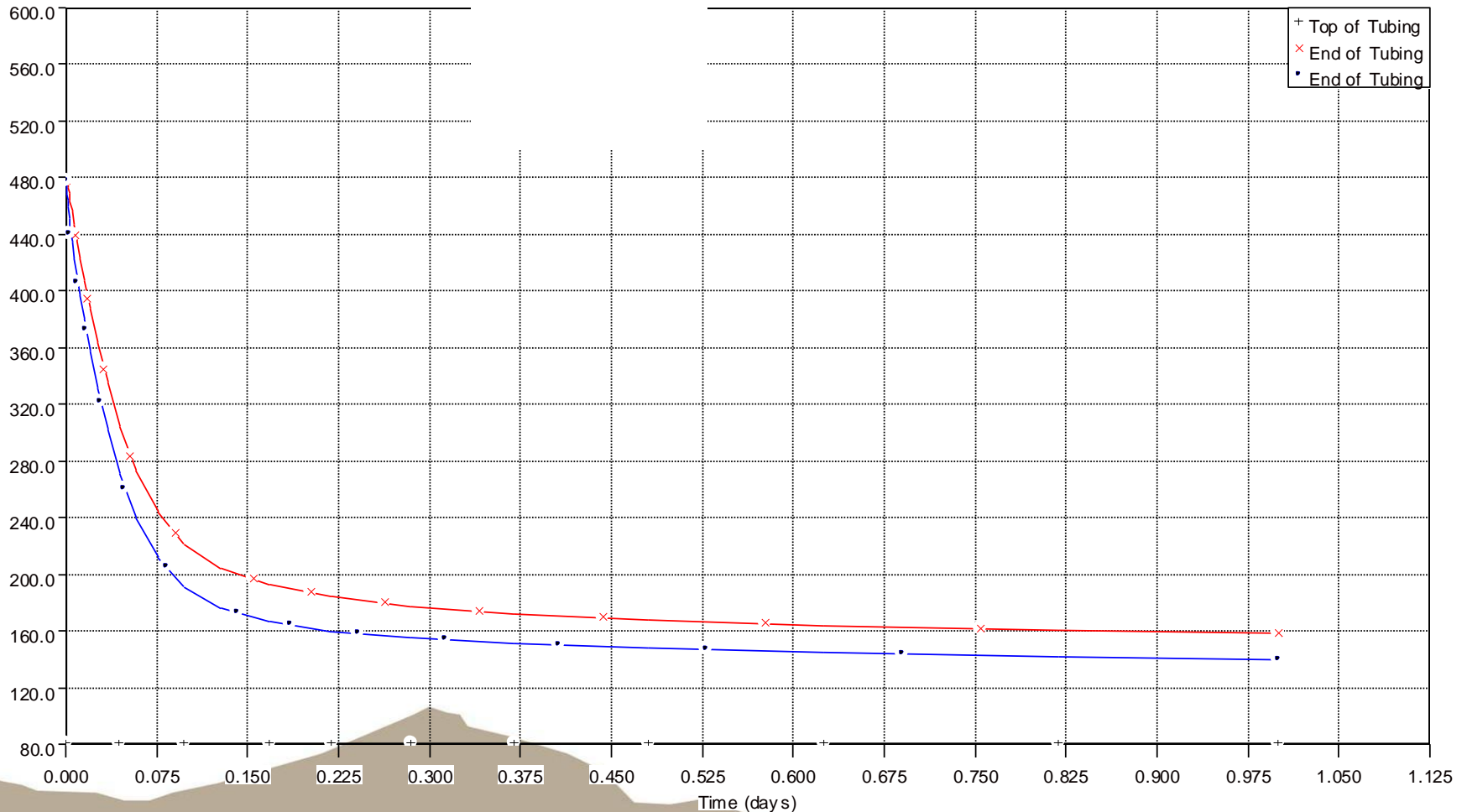

Description of Operation - Test No.1

Goals

- Prove effectiveness of temporary diverter
- Test effectiveness of diverters in slotted liner
- Test effectiveness of diverter in highly permeable, naturally-fractured rock

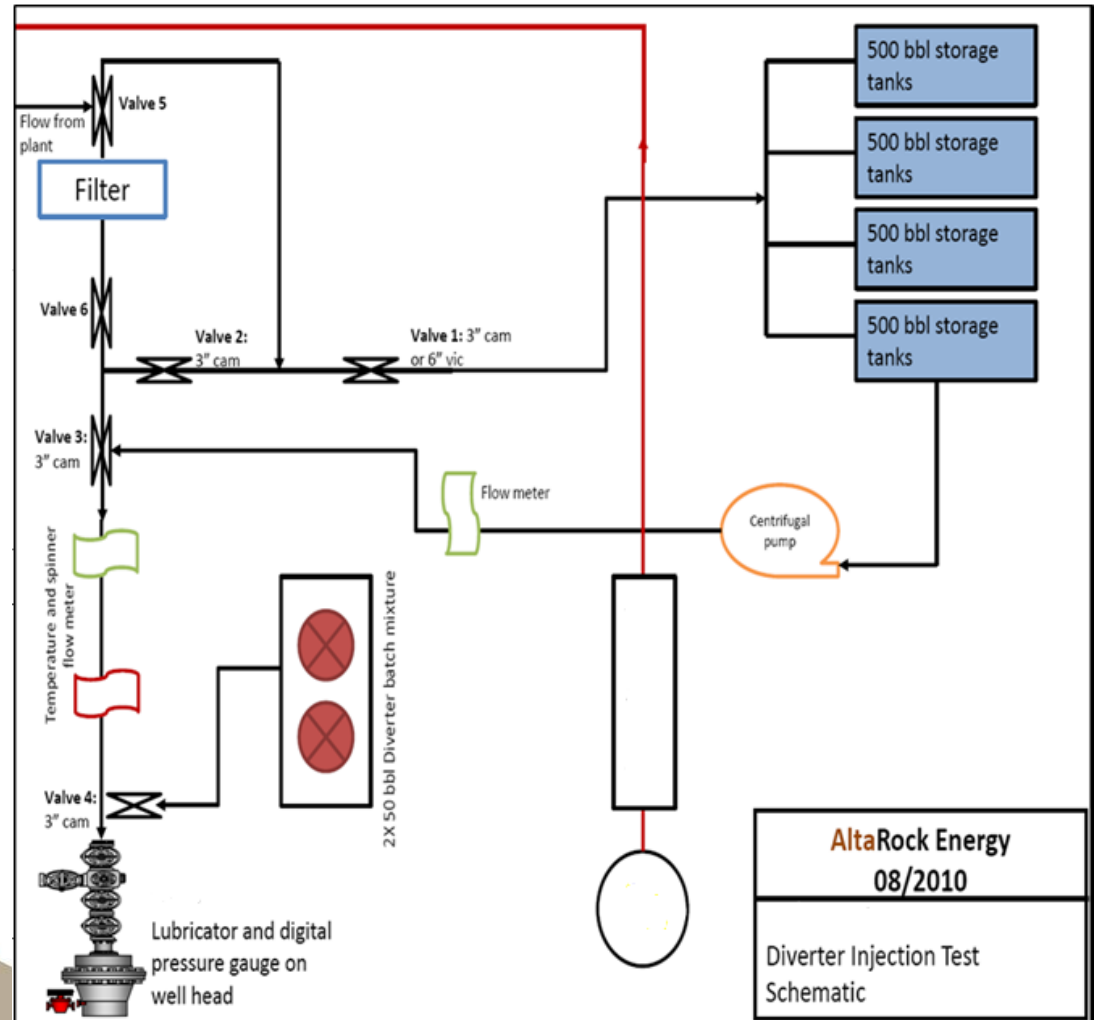

Diverter Test No.1

- Injected water into well prior to the diverter test
- Multiple rates of 150, 300, and 500 gpm
- Measured temperature at bottom of hole
- Repeated 1 Day after injection test
- Repeated 2 Weeks after injection test

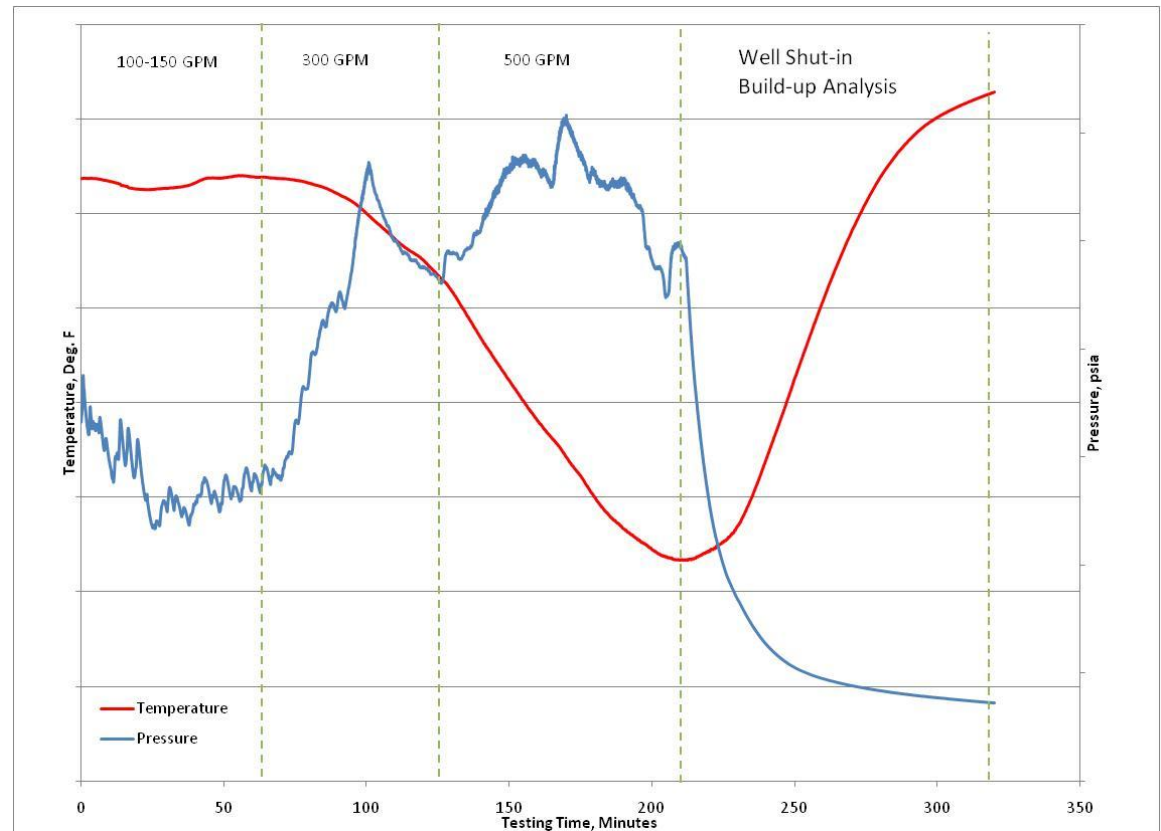

Diverter Test Well

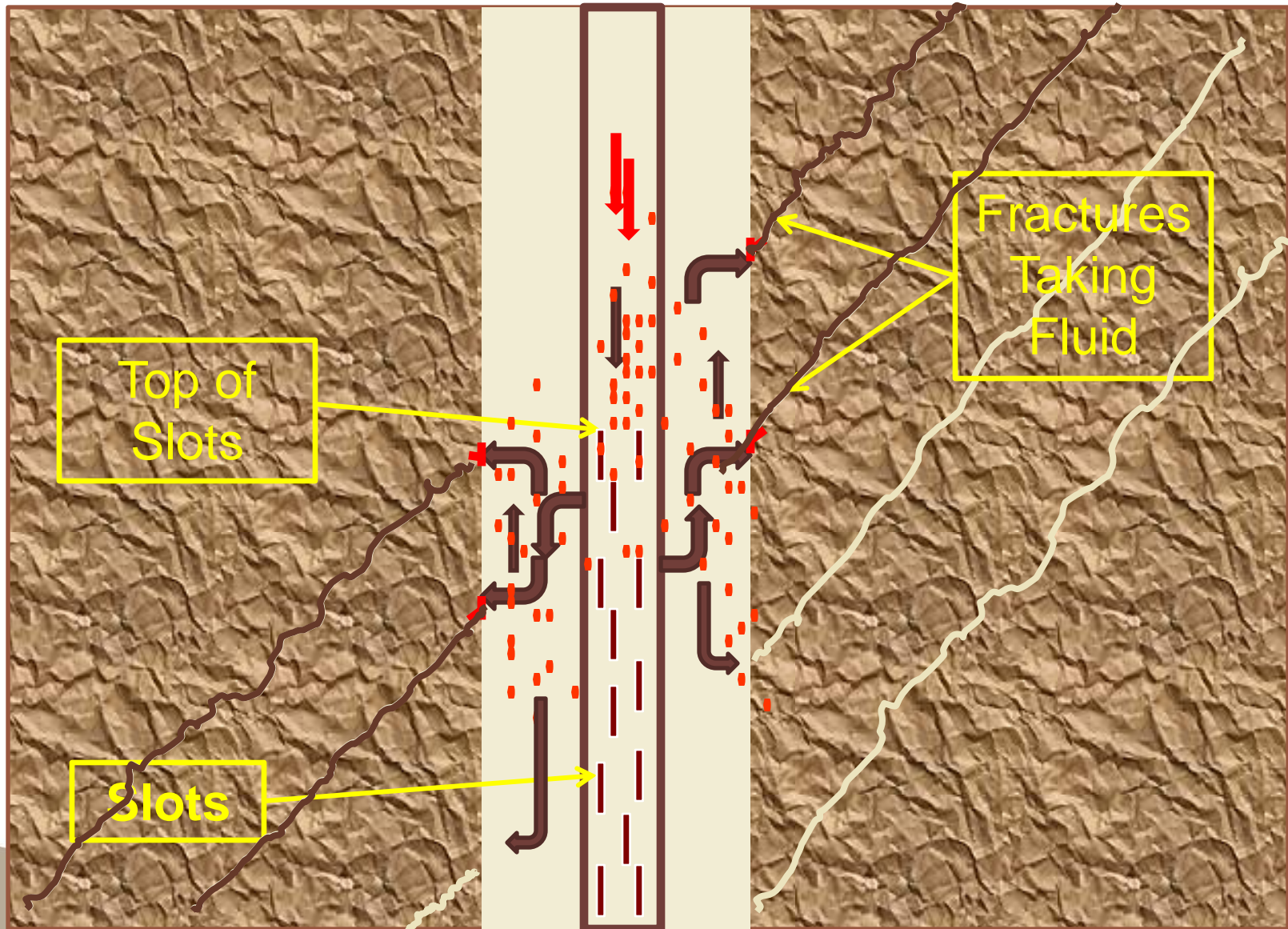

Diverter Test No.1 T & P vs. Time Monitored @ 500 gpm

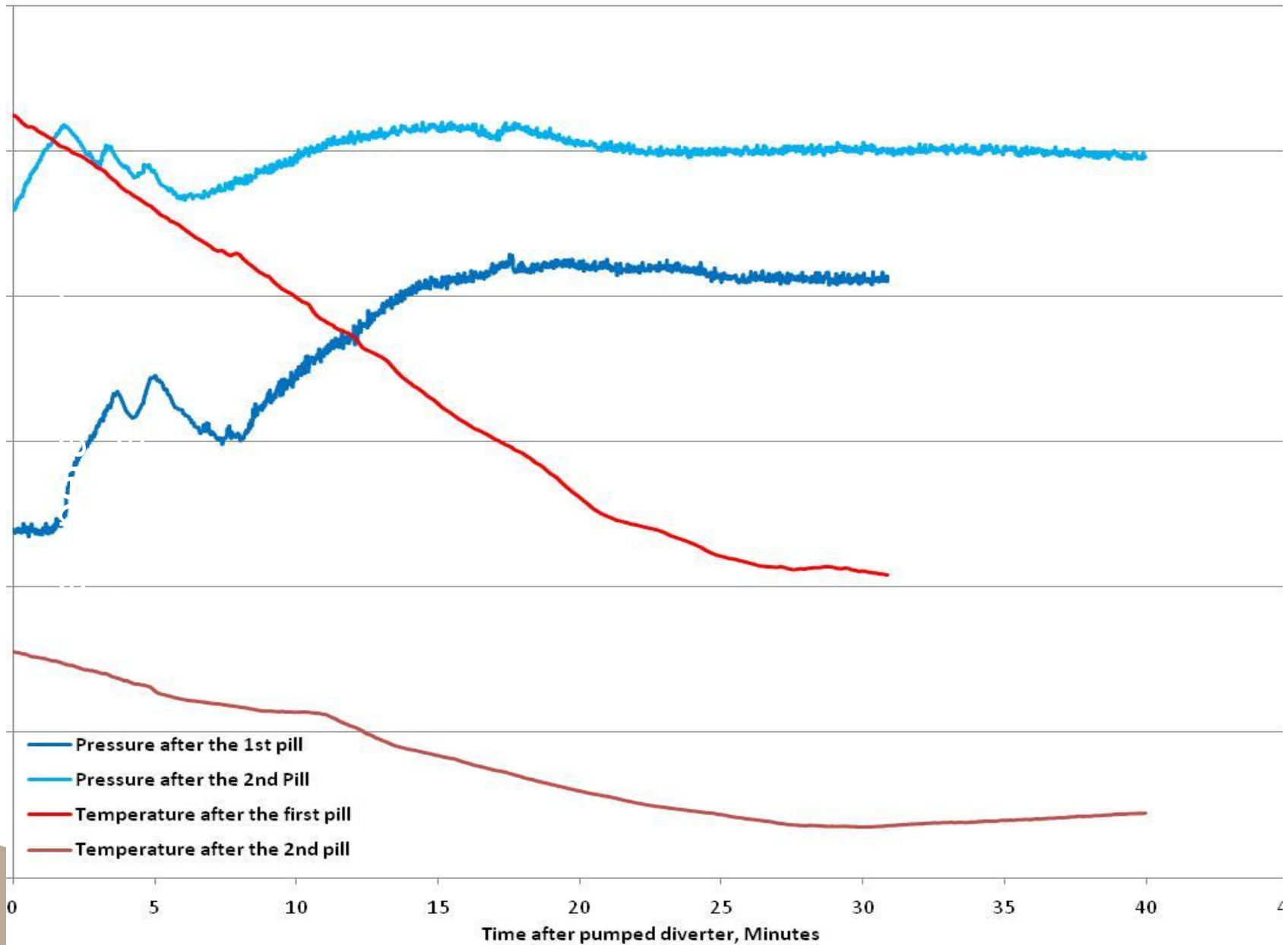

Diverter Test Temperature vs. Depth Monitoring



Injection Pressure Comparison

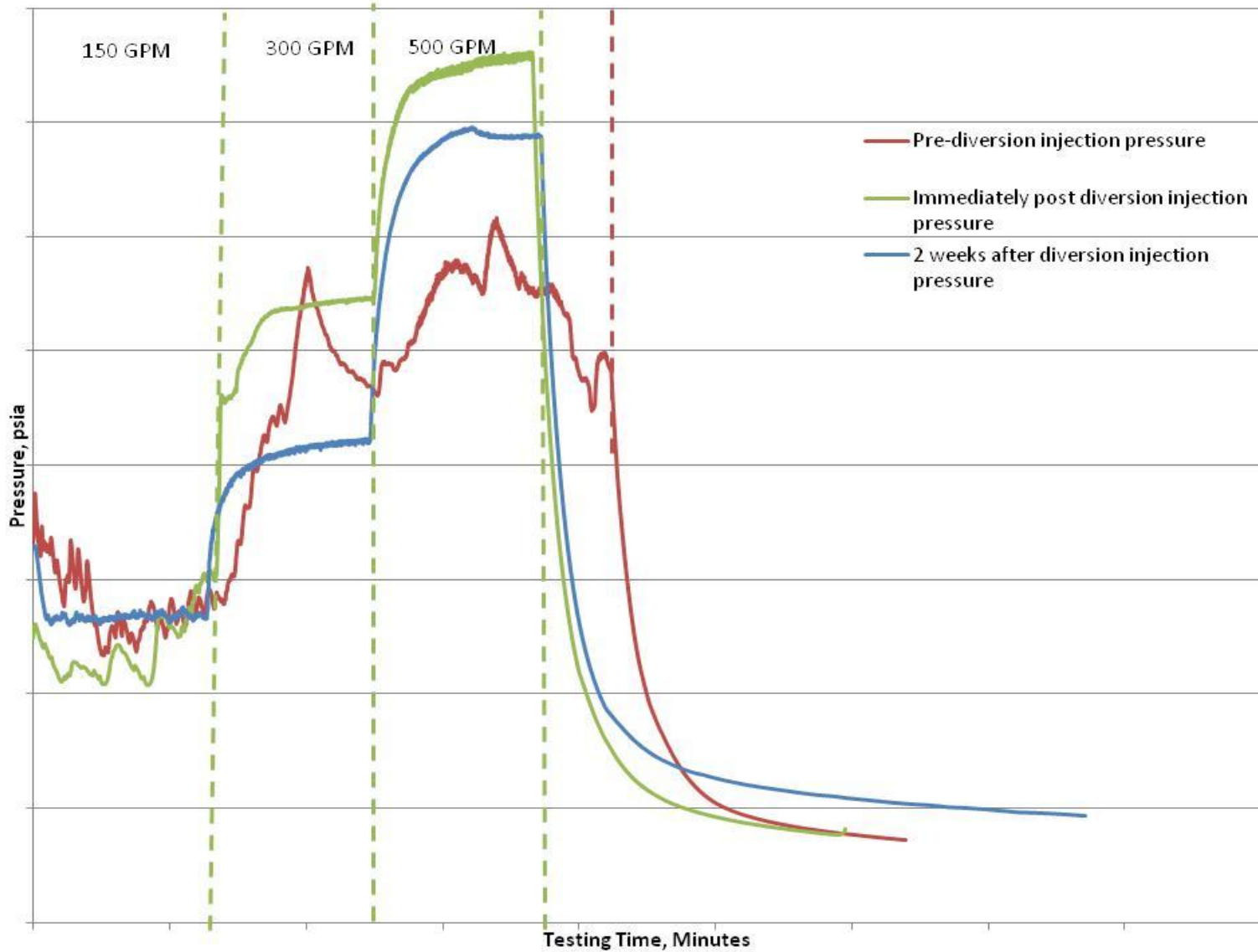

Outcomes & Conclusions - Test No.1

- The first field trial of AltaRock Proprietary Diverter successful
- Highly permeable fractures temporarily sealed
- The presence of a slotted liner with ¼” slots did not pose a problem
- Injection profile in well could be modified temporarily
- Fluid could be pushed deeper into the wellbore
- Finally, transmissivity calculations (kh) before and after the test imply full degradation of the diverter material - value held steady at 55,000 md-ft.

	Injectivity (gpm/psi)	Permeability Thickness (kh) (md-ft)	Permeability (H Estimate) (md)	Injection Zones	Fluid Level, Compared to Pre-Test
Before Diverter Test	1.7	55,021	67.1	4 Injection Zones	Datum
One Day After Diverter Test	0.75	54,731	91.2	4 Injection Zones (Deeper)	150 ft. higher
Two Weeks after Diverter Test	0.85	54,302	181	1 Injection Zone	230 ft. lower

Tracer Test Results - Test No.2

- Stimulated a producing well
- Tracer tests indicate sealing of fast path between stimulated and producers 1 & 2 by diverter during stimulation
- Tracers indicate creation of new flow path(s) between wells

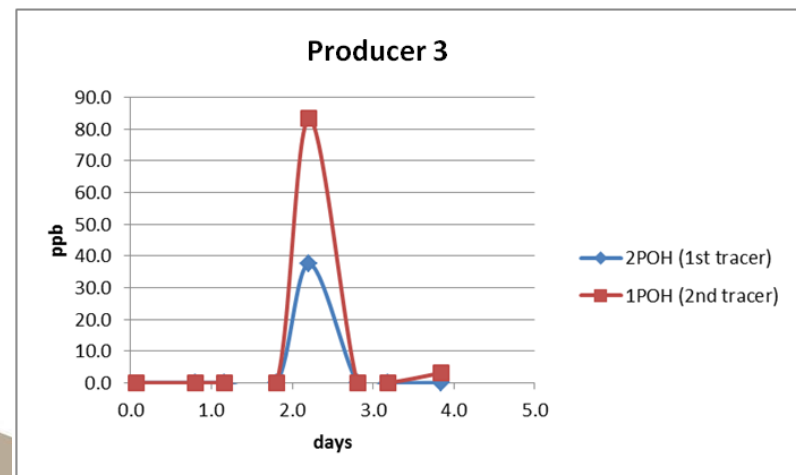
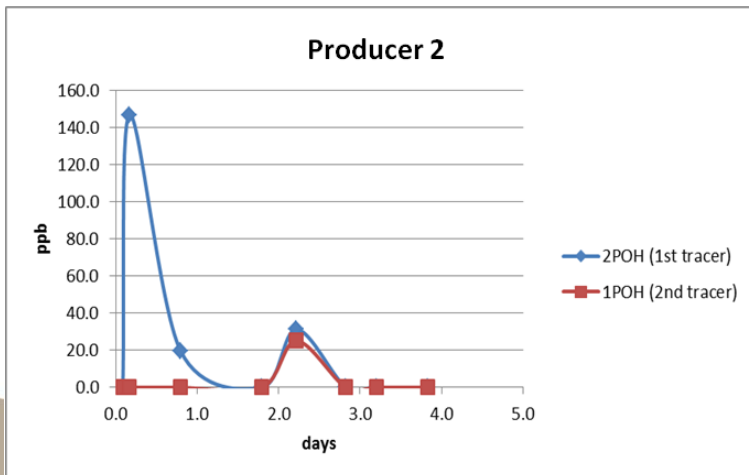
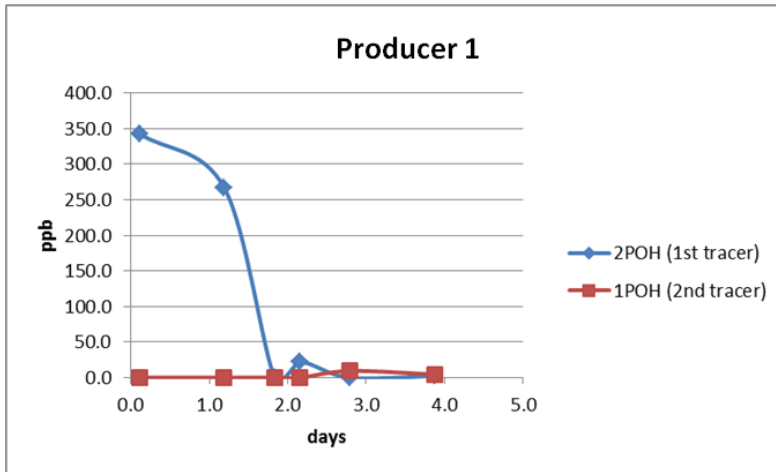

Flow Test Results - Test No.2

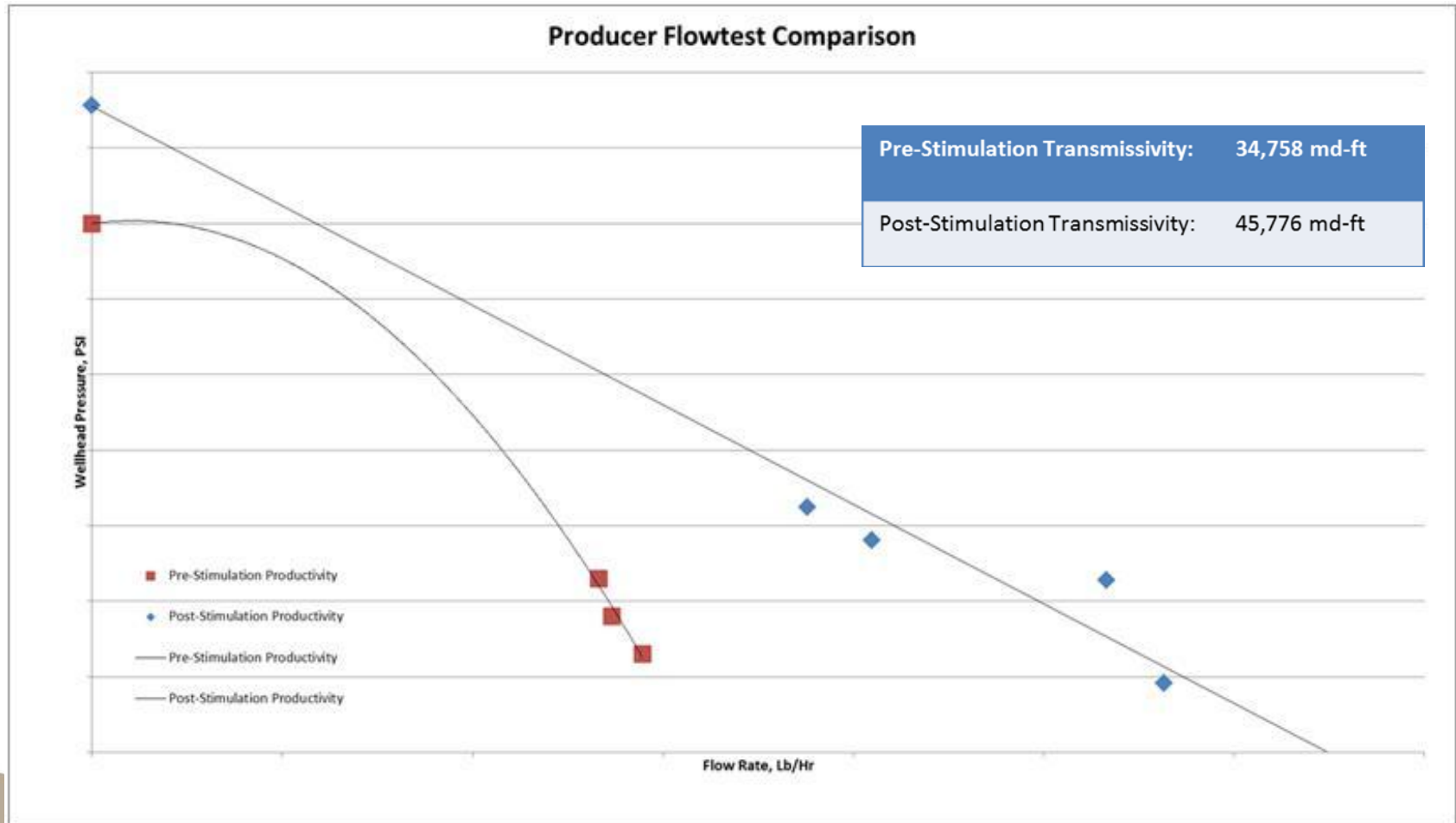

Applications - Test No.2

Stimulation Test w/ Diverters

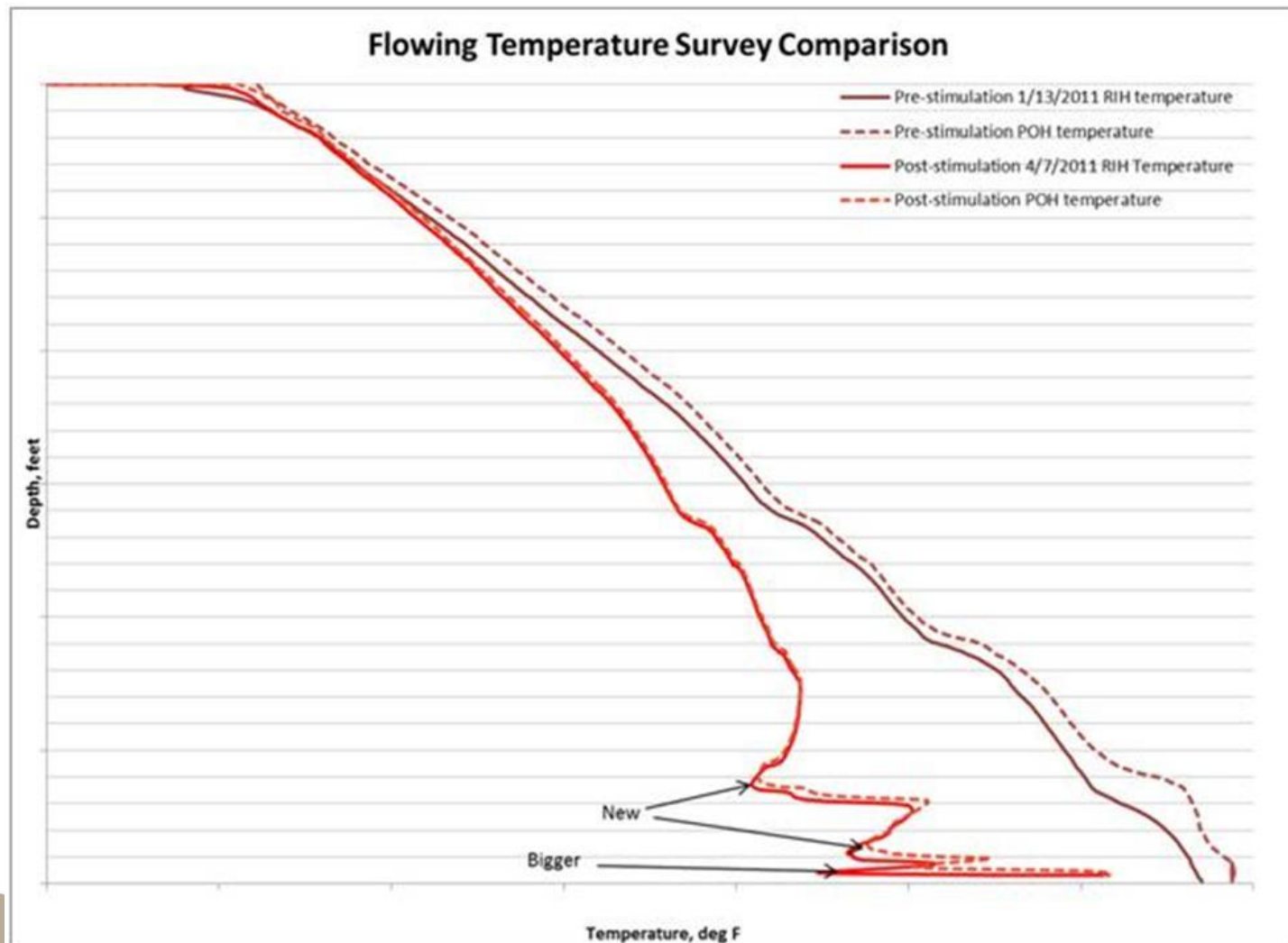

Outcomes & Conclusions - Test No.2

- Successful diversion and stimulation (tracer tests)
- Improved long term production
- Improved permeability due to stimulation (Transmissivity)
- Enhanced production from deeper interval

Conclusions

- AltaRock Proprietary Chemical Diverters have potential to greatly reduce the cost of EGS power and to enhance production of hydrothermal production wells
 - Increase power production on a per well basis
 - GETEM modeling indicates up to 50% or more reduction in power costs
- Field tests provide support of concept of using chemical diverters to temporarily divert flow in actual wells
 - Even with slotted liners already in place

Questions?